



# BLUEPRINT FOR HOME SECURITY

Use this blueprint to help secure doors, windows and other areas of your home. You can take this form down to your local hardware store, and they can help you find the right locks and locking devices to help you be safe at home.

PRUNE OR TRIM SHRUBBERY SO IT DOES NOT BLOCK OUTSIDE VIEW OF EXTERIOR DOORS OR WINDOWS. CONSIDER PLACING PLANTS WITH THORNS OR SPINES, LIKE ROSES, HOLLY OR CACTI UNDER WINDOWS.



DO NOT HIDE DUPLICATE KEYS, GIVE THEM TO TRUSTED NEIGHBOR OR FRIEND

LIGHT ALL EXTERIOR DOORS. WHERE POSSIBLE, INSTALL DUSK TO DAWN TIMERS.

CLOSE AND LOCK GARAGE DOORS. PADLOCKS OFFER BEST PROTECTION.

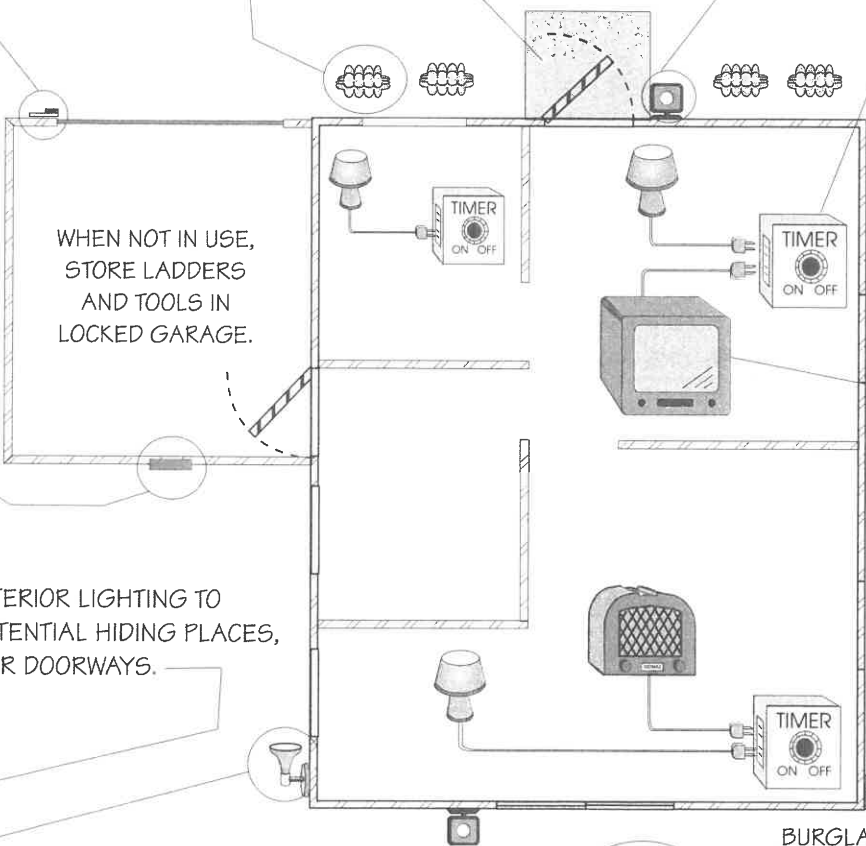

KEEP EXTERIOR CIRCUIT PANEL LOCKED.

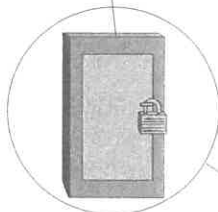

WHEN NOT IN USE, STORE LADDERS AND TOOLS IN LOCKED GARAGE.

USE TIMERS FOR TELEVISIONS, STEREOS, RADIOS, AND LIGHTS. SET IN DIFFERENT PARTS OF THE HOUSE AND HAVE DEVICES COME ON AND GO OFF AT TIMES WHEN TYPICAL RESIDENTS WOULD USE THESE DEVICES.

IDENTIFY ALL VALUABLE, EASILY SOLD ITEMS WITH DRIVER'S LICENSE NUMBER FOLLOWED BY ABBREVIATION OF STATE. CHECK WITH YOUR LOCAL LAW ENFORCEMENT AGENCY FOR PROPER IDENTIFICATION. PHOTOGRAPH ITEMS THAT CANNOT BE MARKED.

USE ADDITIONAL EXTERIOR LIGHTING TO LIGHT ALL DARK, POTENTIAL HIDING PLACES, ESPECIALLY EXTERIOR DOORWAYS.



## BURGLAR ALARMS:

THERE ARE SEVERAL REASONS TO INSTALL A BURGLAR ALARM

1. VALUABLES KEPT AT HOME
2. REMOTE AREA
3. HIGH CRIME AREA OR
4. WANT ADDED PROTECTION.

CHECK WITH RELIABLE ALARM COMPANY FOR MORE INFORMATION ON ALARMS.

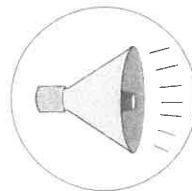

## Why lock up?

44% of burglaries are through unlocked doors and windows (80% of burglars enter through doors and 20% through windows).

60% of rapes in homes are committed by burglars.

3 out of 5 home robberies are committed by burglars.

33% of assaults committed in the home are by burglars.

WHEN INSTALLING HASP, MAKE SURE THERE ARE NO EXPOSED SCREWS WHEN LOCK IS IN PLACE.



QUALITY LOCKS INCLUDE:  
DOUBLE-LOCKING, HARDENED SHACKLE  
LAMINATED STEEL CASE  
PRECISION LOCKING MECHANISM



# Door and Window Security

**VERY IMPORTANT NOTE:** WHEN SECURING DOORS AND WINDOWS, BE SURE TO ALLOW FOR FIRE ESCAPE ROUTES. BE SURE ALL FAMILY MEMBERS KNOW HOW TO UNLOCK DOORS AND WINDOWS.

## HOW TO SECURE A SLIDING WINDOW

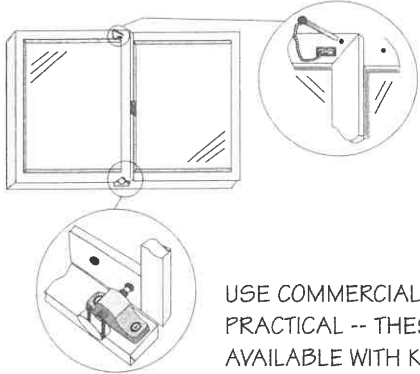

DRILL HOLE THROUGH SLIDING FRAME AND HALFWAY INTO FIXED FRAME. NOTE: DO NOT DRILL COMPLETELY THROUGH FIXED PART OF THE FRAME. (BE CAREFUL NOT TO DRILL THROUGH THE GLASS.)

USE COMMERCIAL LOCKING DEVICE WHERE PRACTICAL -- THESE LOCKS ARE ALSO AVAILABLE WITH KEYS

## HOW TO SECURE A CRANK WINDOW

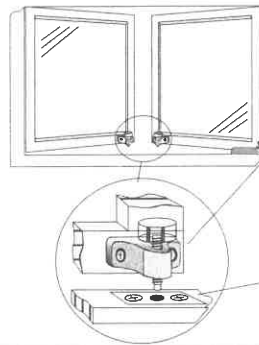

INSTALL COMMERCIAL LOCKING DEVICE ON OUTSIDE CORNER. FOR DOUBLE WINDOWS, USE A LOCKING DEVICE ON BOTH SIDES.

INSERT A METAL STRIKE PLATE IN WOODEN WINDOW SILLS.

## HOW TO SECURE A DOUBLE HUNG WINDOW

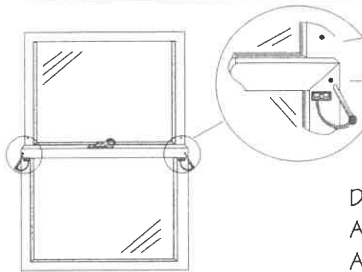

FOR VENTILATION, DRILL SECOND HOLE IN OUTSIDE SASH SO WINDOW CAN BE LOCKED OPEN. ALLOW MAXIMUM OF 3 TO 4 INCHES.

DRILL HOLE (AT DOWNWARD ANGLE) THROUGH INSIDE SASH AND 3/4" INTO OUTSIDE SASH.

USE PIN, NAIL, OR 3/16 EYE BOLT TO SECURE WINDOW

## HOW TO SECURE A LOUVER WINDOW

BECAUSE THEY ARE DIFFICULT TO SECURE, LOUVER WINDOWS SHOULD BE REPLACED. IF UNABLE TO REPLACE, USE TWO-PART EPOXY RESIN TO GLUE GLASS PANELS IN PLACE.

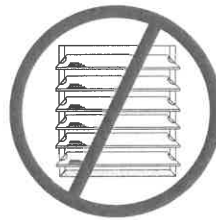

FOR MAXIMUM SECURITY, USE GRILLS FOR BASEMENT OR STREET LEVEL WINDOWS

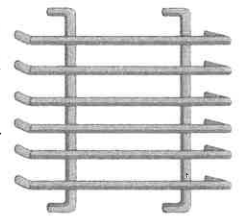

## HOW TO SECURE A HINGED DOOR

HINGES MOUNTED WITH PINS ON INSIDE OR USE PINS THAT CANNOT BE REMOVED

HOW TO SECURE HINGES:

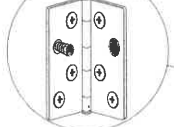

REMOVE SCREW AND REPLACE WITH CUT OFF BOLT THAT PROTRUDES AT LEAST 1/4". DRILL HOLE IN OPPOSITE SIDE SO THAT WHEN THE DOOR IS CLOSED, BOLT WILL PREVENT MOVEMENT.

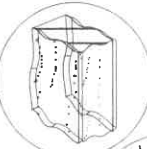
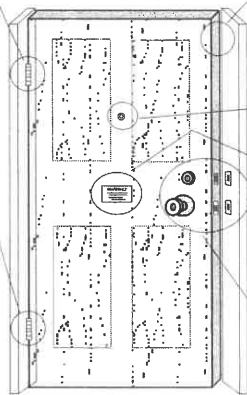

USE ONLY HARDWOOD, SOLID-CORE OR METAL-CLAD FOR ALL EXTERIOR DOORS, INCLUDING THE DOOR TO GARAGE. A LOCK IS ONLY AS GOOD AS THE DOOR IN WHICH IT IS MOUNTED.

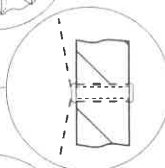

USE WIDE ANGLE (180 DEGREE) DOOR VIEWER (PEEPHOLE) AT EYE LEVEL.

**WARNING:**  
This property has been marked by OPERATION ID, and is recorded with law enforcement authorities.

USE STICKERS AND DECALS TO IDENTIFY YOUR HOME AS A PLACE WHERE EASY PROFITS ARE NOT FOUND. POST NEAR DOOR HANDLES AND LOCKS.

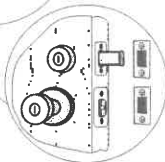

CASE HARDENED DEAD BOLT WITH 1" MINIMUM THROW ON ALL EXTERIOR DOORS. SECURE STRIKE PLATES WITH 3" CASE HARDENED SCREWS. MAKE SURE DOOR JAMB & MOLDINGS ARE SECURE. WHEN MOVING IN, REKEY ALL EXTERIOR LOCKS.

## HOW TO SECURE A SLIDING GLASS DOOR

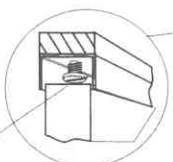

PLACE SCREWS INTO TRACK ABOVE SLIDING DOOR EVERY 8 TO 10 INCHES TO PREVENT DOOR FROM BEING LIFTED OUT OF TRACK.

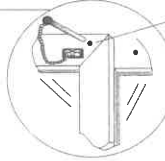
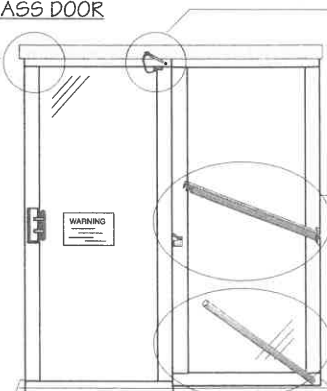

DRILL HOLE THROUGH SLIDING FRAME AND HALFWAY INTO FIXED FRAME. NOTE: DO NOT DRILL COMPLETELY THROUGH FIXED PART OF THE FRAME. (BE CAREFUL NOT TO DRILL THROUGH THE GLASS.)

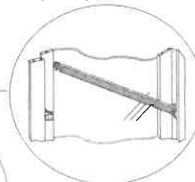

USE LOCKING DEVICE, ALSO CALLED "CHARLIE BAR" IN CENTER OF DOOR. VISIBLE FROM A DISTANCE, IT INFORMS POTENTIAL THIEVES YOU UNDERSTAND HOME SECURITY.

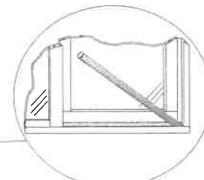

USE DOWEL STOCK OR BROOM HANDLE IN TRACK